

Designed for Automation

Intrinsically Safe High Precision



Rugged

Proven METTLER TOLEDO MonoBloc technology. Stainless steel housing with smooth surface – IP66 in wash-down configuration, trouble-free cleaning with water jet. Built-in overload and torsion protection.



Direct

Efficient data transfer to process control systems via PSU power supply module. Up to three weighing modules connectable to a single power supply module. Optional Profibus DP, DeviceNet or Ethernet communication via accessory modules.



Wash-down Option – IP66

The wash-down option, which is fitted at the factory, is a world-unique seal underneath the weighing plate which is activated by air pressure. It allows the module to be cleaned with a water jet and, at the same time, protects the weighing sensor against dynamic overloading, because in its activated state it blocks the weighing plate. You can see whether or not your weighing module is fitted with the wash-down option from the type designation.

Bellows



Air connection



WM3002X, WM6002X (Zone 1; Class I, Div. 1)

Customer benefits

- Weighing range from 3 kg to 6 kg
- 0.01 g readability
- Directly connects to control systems
- Increase speed and accuracy of filling processes
- Optimizes the use of valuable materials
- Enhances process safety by increasing precision
- Reduces cycle times
- Increases production volume
- Minimizes downtimes
- Equipped for below-the-balance weighing
- Built-in adjustment weight

Model Specific Data WM3002X/WM6002X

Power supply	Unit	WM3002X	WM6002X
Maximum load after switching on with base load (nominal maximum load)	g	3100	6100
Nominal readability	g	0.01	0.01
Repeatability (sd); with factory settings and normal environmental conditions	g	0.01	0.01
Linearity (10 30 °C)	g	± 0.03	±0.04
Base load (equals weight of original weighing platform)	g	260 ¹⁾	260 ¹⁾
Maximum static overload in vertical direction without overload protection	g	4500	9000
Underload starts from	g	-150	-150
Theoretical maximum preload (additional to base load)	g	3100	6100
Maximum preload when adjusting / testing with built-in weight	g	1500	3000
Internal weight loaded indirectly, equals a load of about	g	830	3600
Size of weighing platform with steel cover (standard)	mm	80x80	80x80
Size of weighing platform without steel cover	mm	78x78	78x78
Shortest weighing time for checking a weight of at least 5 % of the maximum weight with a deviation from the final value of	s	0.18	0.21
	g	0.1	0.1
Shortest weighing time for checking a weight of at least 5 % of the maximum weight with a deviation from the final value of	s	0.5	0.55
	g	0.01	0.01
Sensitivity drift during warming-up phase (30 minutes)	g	0.07	0.1
Zero-point drift during warming-up phase (30 minutes)	g	0.15	0.15

¹⁾ The steel cover of the weighing platform (80x80mm) is part of the base load.

General Specifications

Electrical connection	
Power supply	PSU/TBrick-Ex/RS, 100-240 V AC, max. 510 mA
Data interfaces	RS232 via PSU
Data transmission	up to 19 update values per second
Compliance	
Protection type according to ATEX 95	II 2 G EEx ib IIC T4
FM approval	Class I, Division 1, Groups A, B, C, D
CSA	Intrinsic. safe Exi, Class I, GP A, B, C, D, Ex ib IIC T4
Air connection (wash-down version)	
Tube diameter external	4 mm (5/32 inch)
Tube diameter internal	2.5 mm (1/10 inch)
Air pressure (wash-down version)	
Nominal (recommended)	0.5 bar (7.25 psi)
Air pressure maximum	1.0 bar (14.5 psi)
IP protection (in operational state with weighing plate/ platform in place)	
When weighing (protected with double-labyrinth)	IP44
When cleaning wash-down (seal activated with 0.5 bar air pressure)	IP66
Typical service life of seals (normal environmental conditions)	2 years
Allowable ambient conditions	
Operating temperature range	+10 to +30 °C
Allowable ambient temperature range	+5 to +40 °C (40 to 105 °F)
Height above mean sea level	max. 4000 m ¹⁾ (13,330 feet)
Rel. air humidity (use of WM Ex modules only in enclosed interior spaces)	max. 85 % Rh (at 30°C/85°F)
Materials	
Housing, baseplate	Stainless steel 1.4404 (316L)
Weighing platform cover, flange	Stainless steel 1.4301
Weighing plate support 78x78mm	Aluminium, chrome plated
Seal between flange and upper part of housing	NBR 70 Shore A, black, qual. L8030
Seal between baseplate and upper part of housing	NBR, 60-65 Shore A, beige, qual. L7604
Bellows of wash-down version	NBR 50 Shore, black, antistatic, mixture no. 13-NBR/033-50A-0099
Surface roughness of housing	N7 or better

¹⁾ If the AC adapter needed to supply power to the module used at a height greater than 2000 meter above mean sea level, it must fulfill the standards applying for this height)

Accessories



Leveling bubble
42 102 807

Dimensions WM3002X/WM6002X (mm)

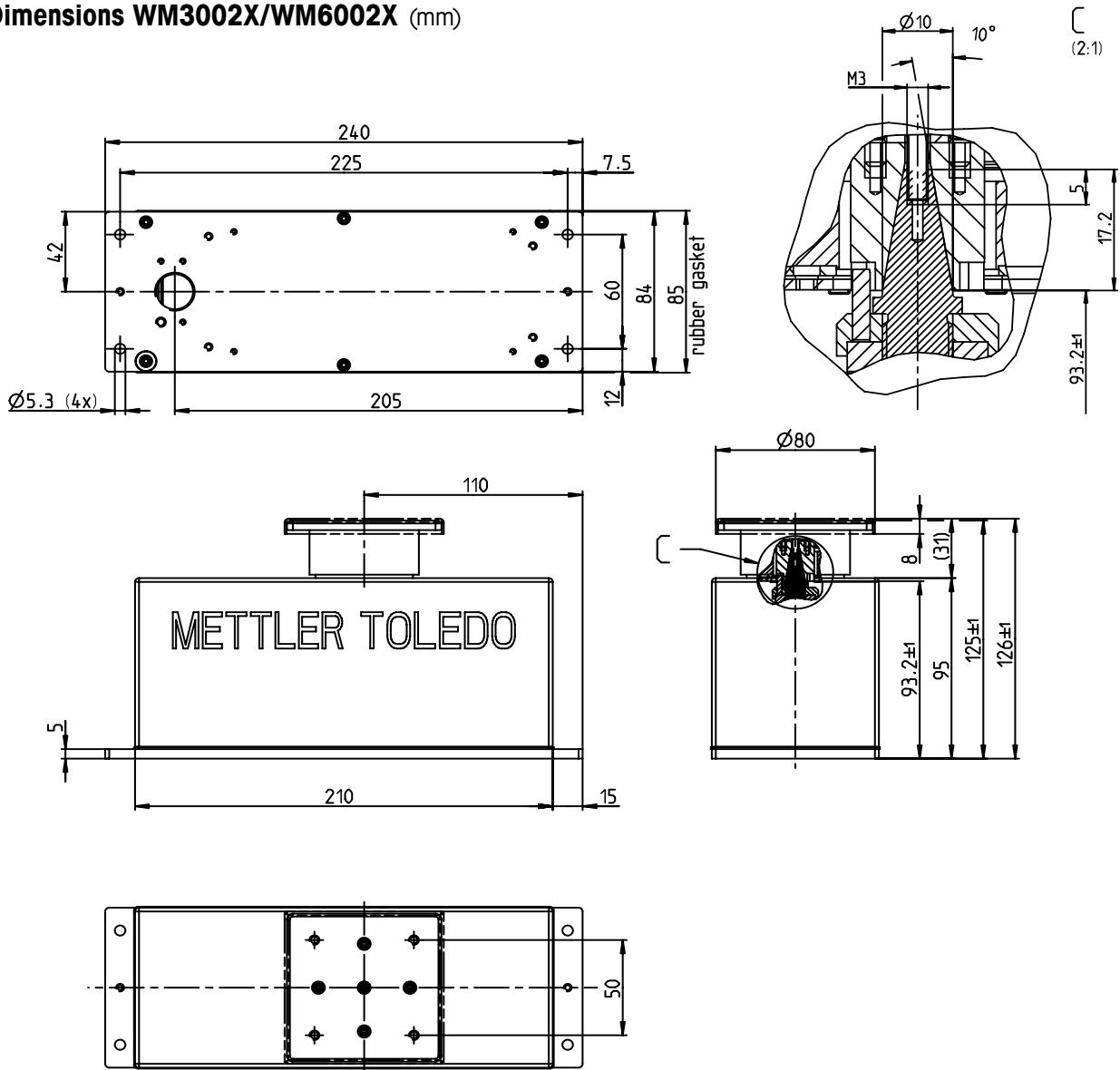

Dimensions Terminal Box (mm)

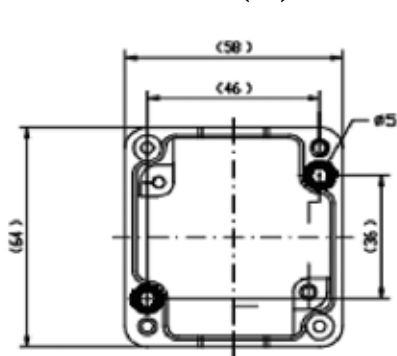

Hole pattern (mm)

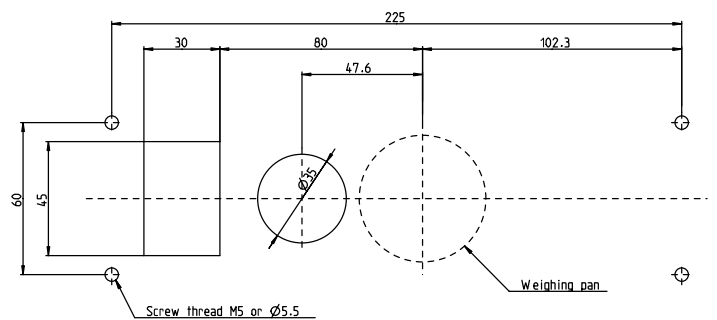

Order Information

Model	Item number	Remarks
WM3002x-LCL	42 102 252	
WM3002x-WCL	42 102 253	Wash-down
WM6002x-LCL	42 102 256	
WM6002x-WCL	42 102 257	Wash-down

Scope of delivery

- Weigh module with weighing platform and attached cable (30 cm)
- Plastic stopper to protect the cone opening
- Terminal box, blue coated incl. supply converter and PG adapter
- 5 m Ex cable, 6-lead
- CD-ROM with product documentation, commissioning software "WM Terminal Display", "WM_e-Loader"
- Instructions for installation and operation
- Reference manual MT-SICS

Typical Configurations

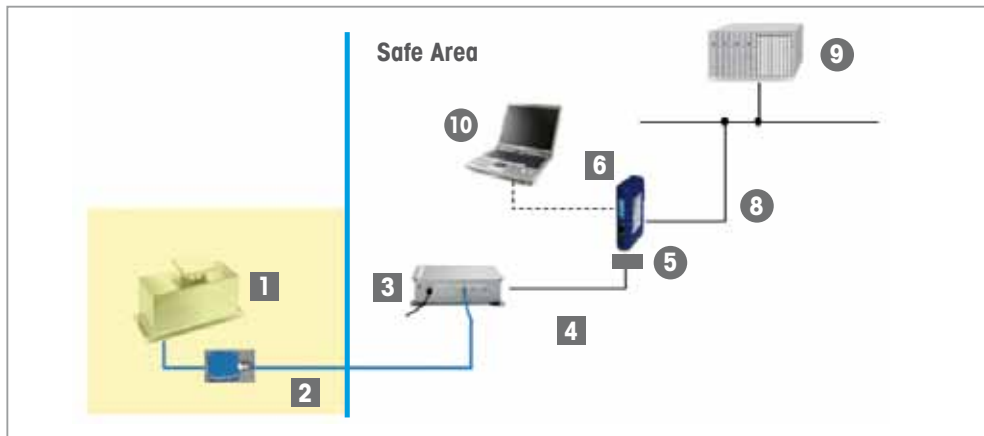

■ Available from
METTLER TOLEDO

● Third party product

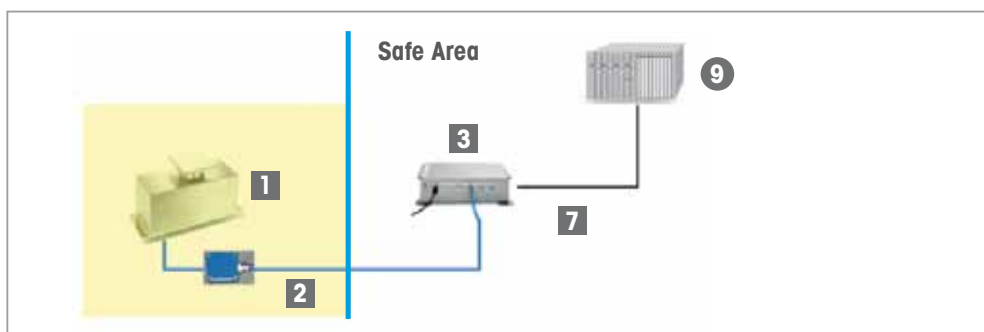

Pos	Item	Description	Item number
1	Weigh Module	WM-Ex module with attached cable 0.3 m	see order information
2	Terminal-Box and 6-wire Ex-cable (5 m)	Included in delivery content of weighing module	
2a	Longer Ex-Cable (option) 6 wire; up to max. 100 m	Longer Ex-cable; connects from Terminal-Box to PSU	00 504 638
3	PSU/TBrick-Ex power supply unit/RS	Power supply unit with power cable, TBrick-Ex slotcard with data conversion module, slotcard interface with RS232 module	22 008 525
3a	Additional Slotcard (option)	To connect a second and third weighing module to the PSU (incl. data conversion, without Ex-cable)	
	TBrick-Ex/RS232	If simultaneously ordered with the PSU	22 008 528
	TBrick-Ex/RS232-PSU	If ordered separately from PSU	22 008 531
4	Serial cable	For the conversion of the 8-pin round plug of PSU to D-Sub 9 male (to connect to Profibus or DeviceNet module)	22 006 795
5	Null Modem or Reversing Adapter	Necessary to crosslink the transmit and receive lines (wired straight through except pin 2 & 3 reversed)	
6	Profibus Module	Incl. connection cable for configuration	42 102 809
6	Profinet Module	Incl. connection cable for configuration	42 102 859
6	DeviceNet Module	Incl. connection cable for configuration	42 102 810
6	Ethernet IP Module	Incl. connection cable for configuration	42 102 860
7	Serial cable (recommended)	For the conversion of the 8-pin round plug of PSU to D-Sub 9 female (to connect to PC or PLC)	00 504 376
8	Customer cable	Fieldbus cable	
9	PLC		
10	PC or Laptop	For configuration and service purpose	



Mettler-Toledo AG

Laboratory & Weighing Technologies
CH-8606 Greifensee, Switzerland
Tel. +41 44 944 22 11
Fax +41 44 944 30 60

Subject to technical changes
© 02/2010 Mettler-Toledo AG
MarCom Industrial

www.mt.com

For more information